

09/2016

Mod: GE-MRX

Production code: MG-02



Diamond
catering equipment

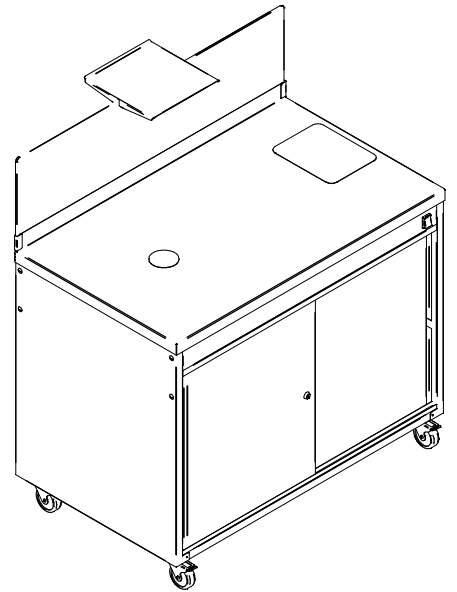
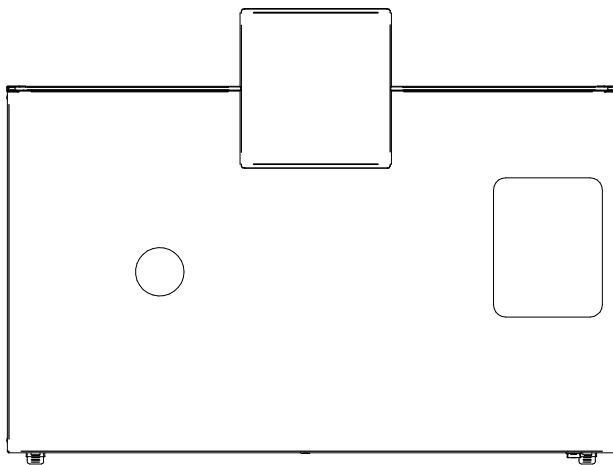
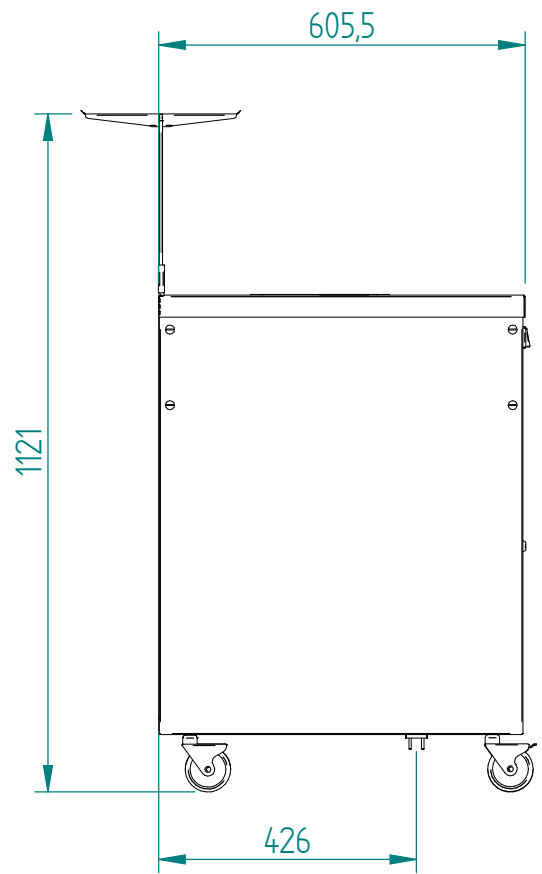
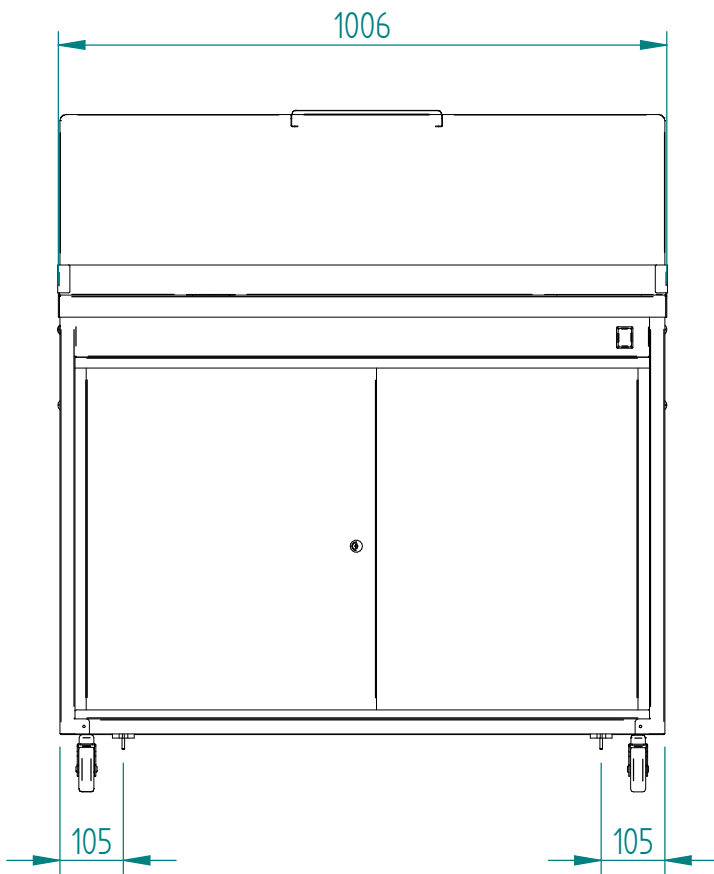

MG-02

Mise en plan

DT171

Date :
13/09/2016

Dessiné par :
R.L

Approuvé par :

Date :
13/09/2016

Indice
A

Produit concerné :	
Code	Cordon / Cord
P05019Z10	C03007
P05019Z12	C03007

MG-02

Cadran

DT171

Date :
13/09/2016

Dessiné par :
R.L

Approuvé par :
J.Godéré

Date :
13/09/2016

Indice
A