

11/2016

# Mod: ICE300MA



**Diamond**  
catering equipment



## Automatic ice cube makers - spray system.

Quality cubes: compact, cold and crystalline.

Modular models, without internal ice storage bin. Must be combined with a collection Bin (different models available). These ice makers can be placed one on the top of another, in pairs (of the same model).

## Produttori automatici di ghiaccio in cubetti - sistema a spruzzo.

Cubetti di qualità: compatti, freddi e cristallini.

Modelli modulari, senza deposito interno di raccolta ghiaccio, occorre abbinarli ad un contenitore di raccolta Bin (disponibile in diversi modelli). Questi produttori sono sovrapponibili a gruppi di 2 (dello stesso modello).



---

---

---

---

---

---

---

---

---

---



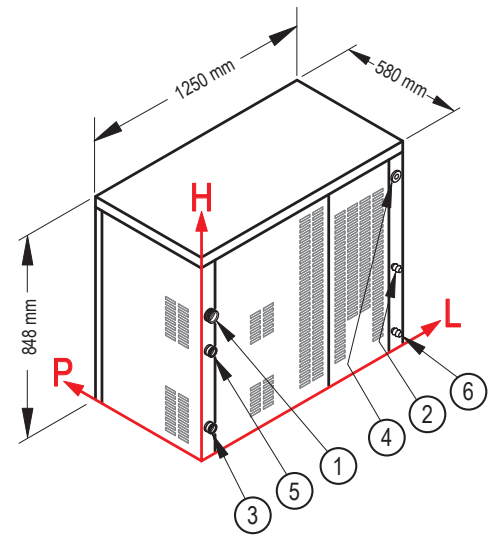
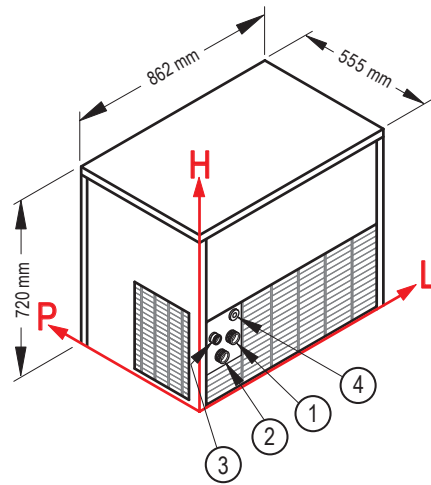
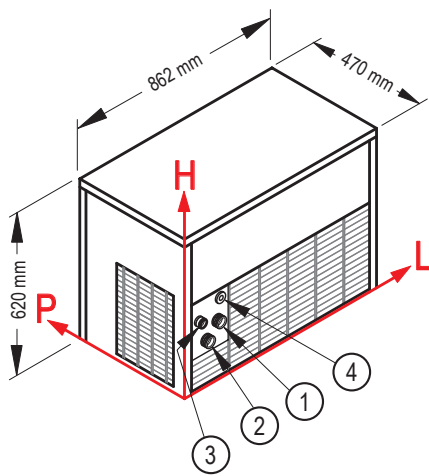

### CONNECTIONS / CONNESSIONI

	L	H	Ø	L	H	Ø	L	H	Ø
① Ice production water inlet / Ingresso acqua produz. ghiaccio	127	213	3/4"	126	284	3/4"	39	582	3/4"
② Condenser water inlet / Ingresso acqua per condensatore *	95	163	3/4"	94	234	3/4"	1217	298	3/4"
③ Water outlet / Scarico acqua	69	226	24 mm	69	297	24 mm	29	73	24 mm
④ Electrical connection / Connessione elettrica	125	284	-	140	355	-	1222	748	-
⑤ Water outlet / Scarico acqua	-	-	-	-	-	-	31	440	24 mm
⑥ Condenser water outlet / Scarico acqua condensatore *	-	-	-	-	-	-	1222	55	3/4"

\* only for water cooling systems / solo per condensazione ad acqua

### TECHNICAL INFORMATION / DATI TECNICI

Production in 24 h / Produzione in 24 h	90 kg	155 kg	300 kg
Cooling system / Condensazione	A - W	A - W	A - W
Kind of cube / Tipo di cubetto	A-18g C-33g D-13g E-42g	A-18g C-33g D-13g E-42g B-60g	A-18g C-33g D-13g E-42g B-60g
Refrigerant / Refrigerante	R404A	R404A	R404A
Usable Bin / Bin utilizzabile	Bin 240 PE - Bin 200	Bin 240 PE - Bin 200 - Bin 350	Bin 350
Standard voltage / Voltaggio standard	220-240 V ~ 50 Hz	220-240 V ~ 50 Hz	220-240 V ~ 50 Hz
Electrical consumption / Consumo elettrico	850 W	1400 W	2600 W
Fuse / Fusibile	10 A	16 A	32 A
Water consumption (l/kg) / Consumo acqua (l/kg)	A 2,2 W 13,5	A 2,6 W 13	A 2,6 W 14,3
Sizes (WxDxH) / Dimensioni [ LxPxH ]	862x470x620 mm	862x555x720 mm	1250x580x848 mm
Sizes with packing (WxDxH) / Dimensioni con imballo [ LxPxH ]	910x520x855 mm	910x605x955 mm	1335x705x1005 mm
Weight (net/gross) / Peso [ netto/lordo ]	83/92 kg	118/128 kg	152/178 kg

Finishing 18/8 stainless steel, scotch brite / Finitura acciaio inox 18/8, scotch brite

Gli apparecchi sono da considerarsi in Classe tropicale (Temperatura ambiente fino a 43°C). / The equipment are to be considered in tropical class (ambient temperature up to 43 °C).

INSTALLATION CONDITIONS / CONDIZIONI D'INSTALLAZIONE	Min / Max
Installation / Installazione	indoor / interna
Ambient temperature / Temperatura ambiente	+10 / +43 °C
Water temperature / Temperatura acqua	+3 / +32 °C
Voltage / Voltaggio	± 10%
Water inlet pressure / Pressione dell'acqua in ingresso	1bar (14psi) / 6bar (84psi)

CONDITIONS / CONDIZIONI	
Standard Cube / Cubetto standard	18g
Ambient temperature / Temperatura ambiente	+21°C
Water temperature / Temperatura acqua	+15°C
Electrical consumption at +43°C (standard voltage) / Consumo elettrico a +43°C (voltaggio standard)	