

09/2016

Mod: 300/TLV

Production code: 15302C2R02IHL



Diamond
catering equipment



Innovative rounded design and no sharp edges or visible screws.
 Chrome plated ground and lapped slide rod.
 Lapped cast iron slide rod bushing.
 Vulcanised rubber stops on carriage.
 Removable support cover for thickness gauge plate.
 Stainless steel slice deflector with snap-on bayonet fitting.
 Stainless steel screws and fittings.
 Bottom cover for accessing electrical components.
 Changeover electronic circuit 110-220-380 V single and three-phase
 Built-in sharpening tool with bottom protection
 Enclosed and sealed belt pulley
 41 mm distance between blade and motor
 Plastic knobs.
 Rubber feet.
 Switch with IP44 protection rating.
 Easy to remove stainless steel meat grip arm.

Data sheet

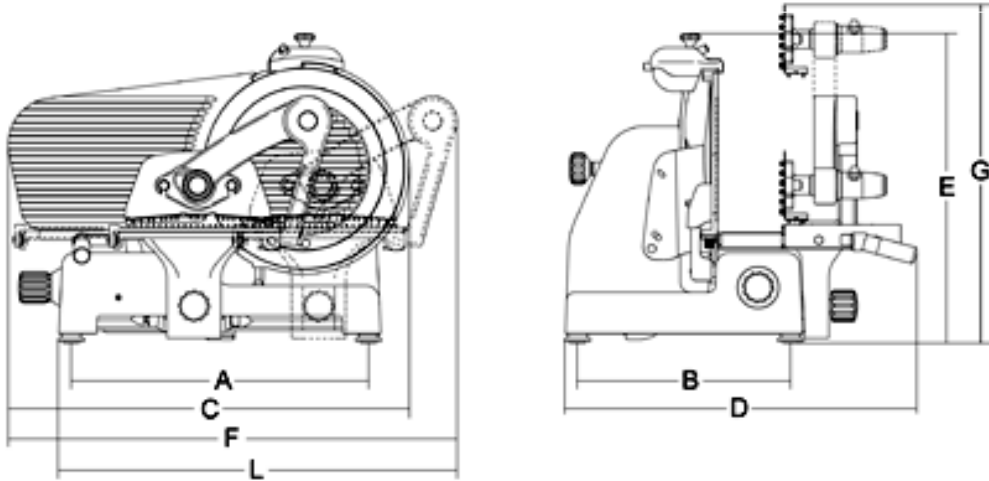

Model	300/TLV
Ø Blade:	mm 300 - inch. 12
Motor:	watt 210 - Hp 0,29
Cut thickness:	mm 30
Run of carriage:	mm 275
Hopper:	mm 275x260
A:	mm 425
B:	mm 320
C:	mm 580
D:	mm 540
E:	mm 460
F:	mm 790
G:	mm 570
L:	mm 620
X:	mm 255
Y:	mm 220
H:	mm 220
W:	mm 220
Net weight:	kg 29
Shipping:	mm 800x600x520
Gross weight:	kg 32
HS-CODE:	84385000