

07/2021

# **Mod:WR-FTG-Z2**

**Production code: FTH-60G**

# gas griddle plates

Snack units are made of AISI 430 stainless steel with AISI 304 top plate. All snack units include pressed top plate or basins with round internal angles and ergonomic front panels. All connection points are located on the device rear side. Wide selection of models and options helps in setting up a compact customized configuration.



- Selection of modules of 330, 660, 990 mm width
- The option of several surface variants and the plate materials. Smooth or ribbed surface, the option of surface combination. The plate material is steel or hard chrome steel
- Griddle plate thickness is 10 mm – it guarantees smaller temperature fluctuation
- Plate rim (space coverage) is welded on both sides
- Fat drawer with 1 litre volume
- Possible variant with safety thermostat
- Gas regulation by means of the regulation knob
- The burner ignition is provided by integrated piezo lighter



FTH 30 G  
FTCH 30 G



FTR 30 G  
FTRC 30 G



FTH 60 G  
FTCH 60 G



FTTH 60 G  
FTTHRC 60 G



FTH 90 G  
FTCH 90 G

Index	Model	mm	kg	kW	Plates	Plates	° C
101 000 300 101 000 302	FTH 30 G FTCH 30 G	330 x 600 x 220	24,3	4	480 X 320	Smooth Smooth chromed	50 - 300
101 000 800 101 000 802	FTR 30 G FTRC 30 G	330 x 600 x 220	24,3	4	480 X 320	Grooved Grooved chromed	50 - 300
101 001 300 101 001 302	FTH 60 G FTCH 60 G	660 x 600 x 220	44,9	8	480 x 650	Smooth Smooth chromed	50 - 300
101 001 800 101 001 802	FTTH 60 G FTTHRC 60 G	660 x 600 x 220	44,9	8	480 x 650	Combined Combined chromed	50 - 300
101 001 310 101 001 320	FTH 90 G FTCH 90 G	990 x 600 x 220	76,4	12	480 x 970	Smooth Smooth chromed	50 - 300

# gas griddle plates

## FT 30

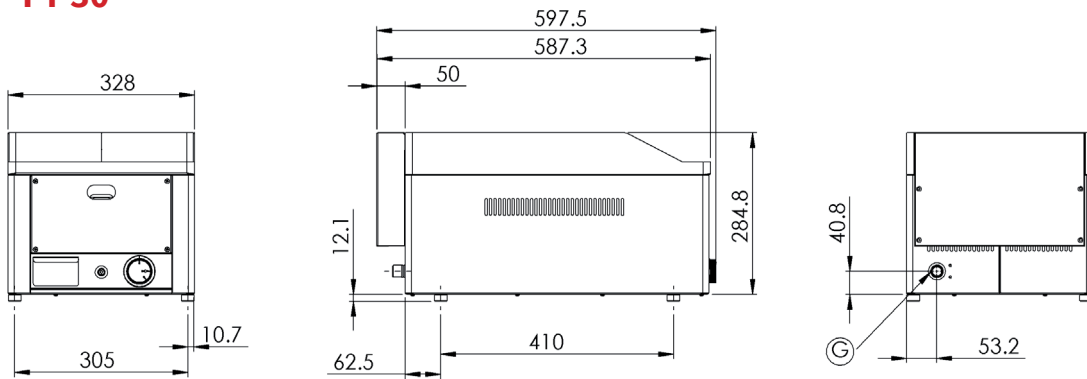

## FT 60

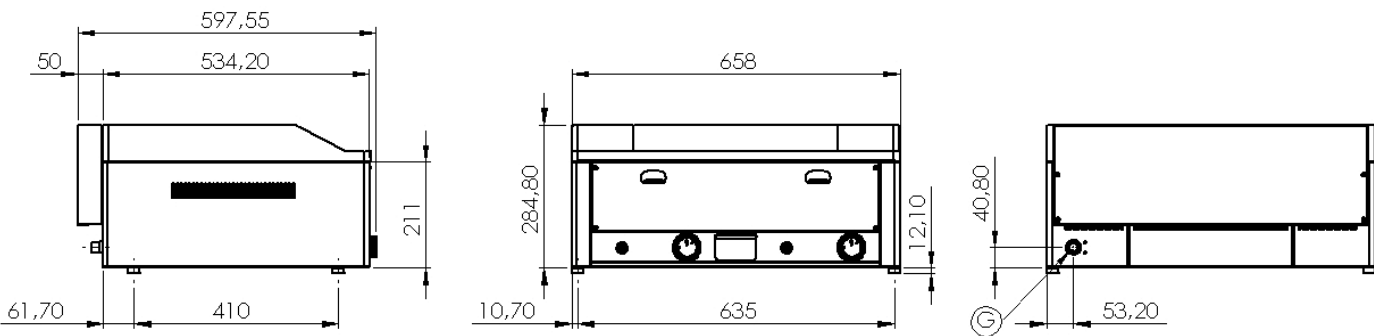

## FT 90

