

04/2015

Mod: EMB/200I

Production code: P436 31220 (PTBC IE200)



Diamond
catering equipment

TILTING PANS

PTBC
Model

These are automatic tilting cooking pots, with lateral support uprights. These models are designed for cooking solid foods that are transferred by tipping of the container. On request, they are fitted with a 2" spout for emptying the liquids involved in the cooking process.

TECHNICAL FEATURES

Cooking tank

- Cooking tank with bottom in AISI 316 polished stainless steel and walls in AISI 304 stainless steel

Jacket (indirect heated version)

- Jacket with bottom and walls in AISI 304 stainless steel

Lid

- Balanced lid in AISI 304 stainless steel with heat resistant handle

SUPPORT FRAME AND PANELS

- Stainless steel frame
- Thermal insulation assured by high density ceramic fibre 64/128
- Panels in AISI 304 stainless steel, fine satin finish

Tilting of the container

- Automatic tilting with hydraulic drive
- Electric supply: 400V 3N 50Hz

Heating system

Direct Gas versions

- Heating by means of AISI 304 stainless steel high efficiency tube burners
- Ignition by means of manual piezo-electric lighter and pilot flame
- Valve-controlled safety tap with thermocouple
- Safety thermostat
- Venting grid
- Set of jets for different types of gas



Indirect Gas versions - with Jacket

- Heating by means of AISI 304 stainless steel high efficiency tube burners
- Ignition by means of manual piezo-electric lighter and pilot flame
- Valve-controlled safety tap with thermocouple
- Venting grid
- Set of jets for different types of gas
- Jacket water level control taps max/min with the option of automatic filling
- Jacket pressure control by means of spring-loaded safety relief valve calibrated at 0,5 bar, vacuum valve and pressure gauge

Indirect Electric versions - with Jacket

- Heating by means of INCOLOY heating elements with adjustable power regulator
- Safety thermostat to prevent overheating and keeps the equipment from operating without water
- Jacket water level control taps max/min with the option of automatic filling
- Jacket pressure control by working pressure switch and spring-loaded safety relief valve calibrated at 0,45 bar, vacuum valve and pressure gauge
- Standard power supply 400V 3N 50Hz

Indirect Steam versions - with Jacket

- Heating by means of steam (from user's plant line) with a throttle valve allowing a gradual steam inlet
- Jacket pressure control by means of spring-loaded safety relief valve calibrated at 0,45 bar, vacuum valve and pressure gauge

PTBC	V	IE	GD	IG
Automatic tilting	●	●	●	●
Jacket safety assembly	●	●	-	●
Water tap	●	●	●	●
Draining tap 2" conical size	*	*	*	*
Draining tap 2" AISI 316	*	*	*	*
Drain spout filter	*	*	*	*
Valve-controlled safety tap with thermocouple	-	-	●	●
Safety thermostat	-	●	*	●
Pressure switch	-	●	-	*
Electronic water filling in jacket with probe	-	*	-	*
Electronic temperature control of cooking tank with display	*	*	*	*
Electronic temperature indicator of cooking tank with display	*	*	*	*
Electric cooking time control with display and buzzer	*	*	*	*
HACCP parameters acquisition with display and RS485 output	*	*	*	*
HACCP parameters acquisition with register + printer in paper roll (box for wall)	*	*	*	*
HACCP parameters acquisition software for PC	*	*	*	*
Manual jacket air venting	●	●	-	●
Automatic jacket air venting	*	*	-	*
Colander basket	*	*	*	*

- standard
- * optional
- no

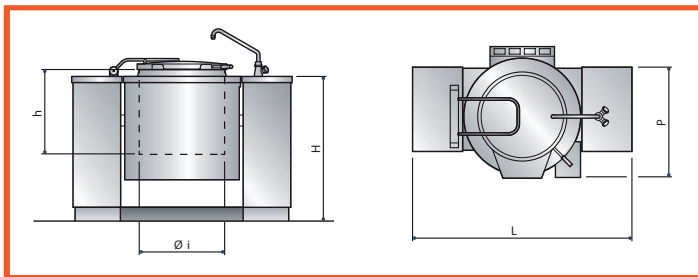

MODEL	Capacity liter	Pan Dimensions L x P x H mm	Tank Dimensions Ø i x H mm	Power (kW)		Consumption			
				Gas	Electric	L. P. G. kg/h	Nat. Gas H m³/h	Nat. Gas L m³/h	Steam kg/h
PTBC V100	100	1600x850x1050	Ø600x420	-	0,2	-	-	-	60
PTBC V150	150	1600x850x1050	Ø600x540	-	0,2	-	-	-	65
PTBC V200	200	1750x1000x1050	Ø760x500	-	0,5	-	-	-	85
PTBC V300	300	1950x1200x1300	Ø960x500	-	0,5	-	-	-	100
PTBC V500	500	2050x1300x1300	Ø1060x600	-	0,5	-	-	-	115
PTBC IE100	100	1600x850x1050	Ø600x420	-	12,2	-	-	-	-
PTBC IE150	150	1600x850x1050	Ø600x540	-	16,2	-	-	-	-
PTBC IE200	200	1750x1000x1050	Ø760x500	-	24,5	-	-	-	-
PTBC IE300	300	1950x1200x1300	Ø960x500	-	36,5	-	-	-	-
PTBC IE500	500	2050x1300x1300	Ø1060x600	-	48,5	-	-	-	-
PTBC GD100	100	1600x850x1050	Ø600x420	24	0,2	1,86	2,48	2,46	-
PTBC GD150	150	1600x850x1050	Ø600x540	24	0,2	1,86	2,48	2,46	-
PTBC GD200	200	1750x1000x1050	Ø760x500	39	0,5	3,47	4,66	5,41	-
PTBC GD300	300	1950x1200x1300	Ø960x500	39	0,5	3,47	4,66	5,41	-
PTBC GD500	500	2050x1300x1300	Ø1060x600	55	0,5	4,62	6,21	7,21	-
PTBC IG100	100	1600x850x1050	Ø600x420	24	0,2	1,74	2,74	2,3	-
PTBC IG150	150	1600x850x1050	Ø600x540	24	0,2	1,74	2,74	2,46	-
PTBC IG200	200	1750x1000x1050	Ø760x500	39	0,5	3,47	4,66	5,41	-
PTBC IG300	300	1950x1200x1300	Ø960x500	48	0,5	3,47	4,66	5,41	-
PTBC IG500	500	2050x1300x1300	Ø1060x600	55	0,5	4,62	6,21	7,21	-

- V: steam
- IE: indirect el.
- GD: direct gas
- IG: indirect gas

INSTALLATION DIAGRAM

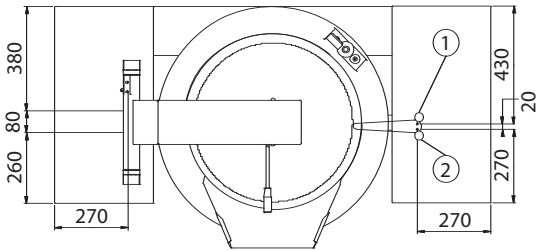
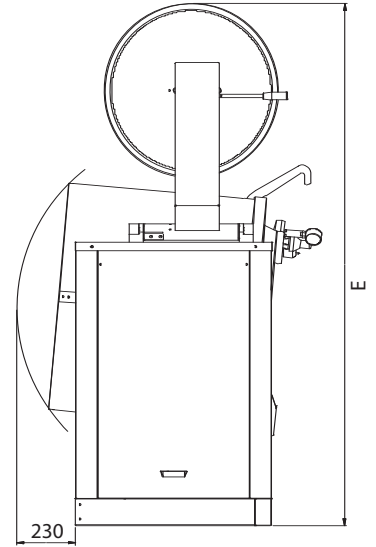
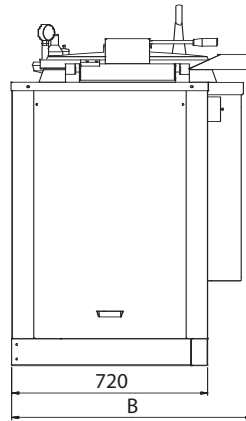
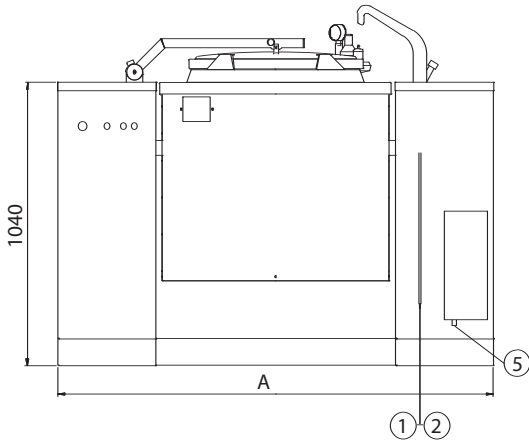

	100	150	200	300	500
A	1600	1600	1800	1950	-
B	885	885	1100	-	-
E	1920	1920	2100	-	-

IT

INDICE PARTI MECCANICHE

- 1 ATTACCO ACQUA CALDA Ø1/2" F
- 2 ATTACCO ACQUA FREDDA Ø1/2" F
- 5 ALLACCIAMENTO ELETTRICO

GB

INDEX OF MECHANIC PARTS

- 1 HOT WATER CONNECTION Ø1/2" F
- 2 COLD WATER CONNECTION Ø1/2" F
- 5 ELECTRICAL CONNECTION

DE

VERZEICHNIS DER MECHANISCHEN TEILE

- 1 ANSCHLUSS WARMWASSER Ø1/2" F
- 2 ANSCHLUSS KALTWASSER Ø1/2" F
- 5 STROMZUFUHR ELEKTROLEITUNGEN

FR

LEGENDE PARTIES MECANIQUES

- 1 RACCORD EAU CHAUDE Ø1/2" F
- 2 RACCORD EAU FROIDE Ø1/2" F
- 5 ARRIVEE CABLES ELECTRIQUES

SP

ÍNDICE PARTES MECÁNICAS

- 1 CONEXIÓN AGUA CALIENTE Ø1/2" F
- 2 CONEXIÓN AGUA FRÍA Ø1/2" F
- 5 CONEXIÓN ELÉCTRICA

PT

ÍNDICE PARTES MECÁNICAS

- 1 LIGACÃO DA ÁGUA QUENTE Ø1/2" F
- 2 LIGACÃO DA ÁGUA FRÍA Ø1/2" F
- 5 LIGAÇÃO ELÉCTRICA