

05/2015

Mod: TCX32/ND

Production code: 21329002F



Diamond
catering equipment

Meat Grinders, model TC 32 Colorado:



- AISI 304 stainless steel construction.
- Powerful IP 55 insulated and fan-cooled motors for continuous use.
- Endless screw motor-reducer running in an oil-bath enables a long service life .
- Motor-reducer equipped with a double seal for long, trouble-free service.
- Convenient, no-tools head lock mechanism.
- Stainless steel mincing head carefully designed for high yield production, completely removable for ease of cleaning.
- Feed tray provided with safety interlock CE versions.
- IP 54 protected, 24 V controls.

Optional:

- Interlock protection for more than 8 mm holes plates (An interlock protection system is required in order to utilize more than 8 mm holes plates).
- Partial or total Unger system mincing head.
- Plexiglass feed tray lid.
- Stainless steel IP 67 protected controls.



Optional Format M

Data sheet

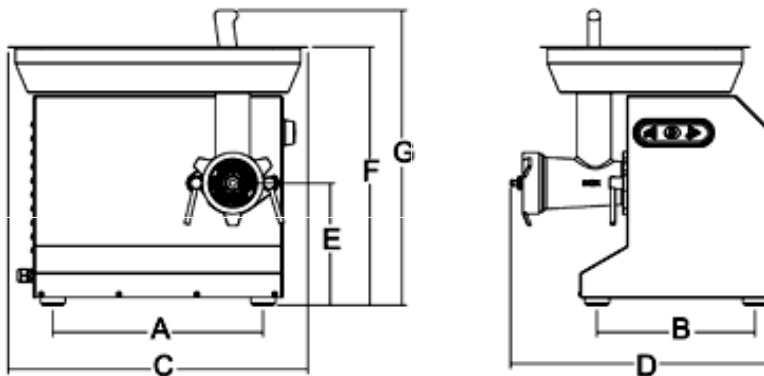

Technical data

Model	TC 32 COLORADO
Power	watt 2205 - Hp 3
Power source	230-400V/50Hz
Output/h.	kg/h. 400
Standard plate	ø mm 4,5
B	mm 440
C	mm 296
D	mm 610
E	mm 479
F	mm 228
G	mm 462
Net weight	Kg 39
Shipping	mm 720x570x770
Gross weight	Kg 61
HS-CODE	84385000