

05/2015

Mod: TCX22/NC

Production code: 21229002F



Diamond
catering equipment

Meat Grinders, model TC 22 Colorado:



- AISI 304 stainless steel construction.
- Powerful IP 55 insulated and fan-cooled motors for continuous use.
- Endless screw motor-reducer running in an oil-bath enables a long service life.
- Motor-reducer equipped with a double seal for long, trouble-free service.
- Convenient, no-tools head lock mechanism.
- Stainless steel mincing head carefully designed for high yield production, completely removable for ease of cleaning.
- IP 54 protected, 24 V controls.

Optional:

- Interlock protection for more than 8 mm holes plates (An interlock protection system is required in order to utilize more than 8 mm holes plates).
- Partial or total Unger system mincing head .
- Plexiglass feed tray lid.
- Stainless steel IP 67 protected controls.



Optional Format M



Data sheet

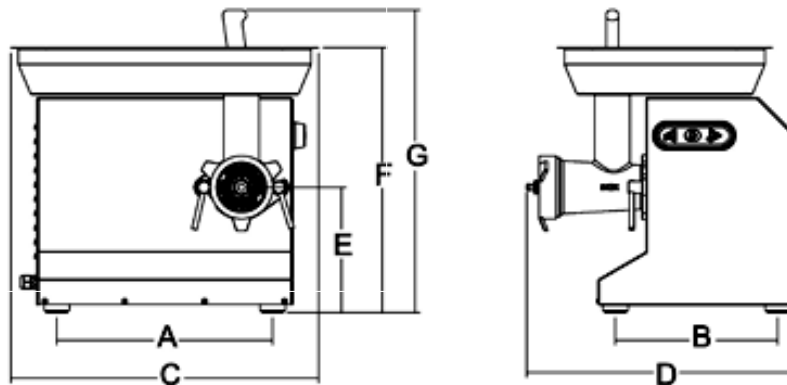

Technical data

Model	TC 22 COLORADO
Power	watt 1470 - Hp 2
Power source	230-400V/50Hz
Output/h.	kg/h. 300
Standard plate	ø mm 4,5
A	mm 360
B	mm 296
C	mm 500
D	mm 415
E	mm 205
F	mm 432
G	mm 568
Net weight	Kg 32
Shipping	mm 600x500x500
Gross weight	Kg 35
HS-CODE	84385000