

11/2013

Mod: **CSP2/9V**

Production code: 40802102EHL



Diamond
catering equipment

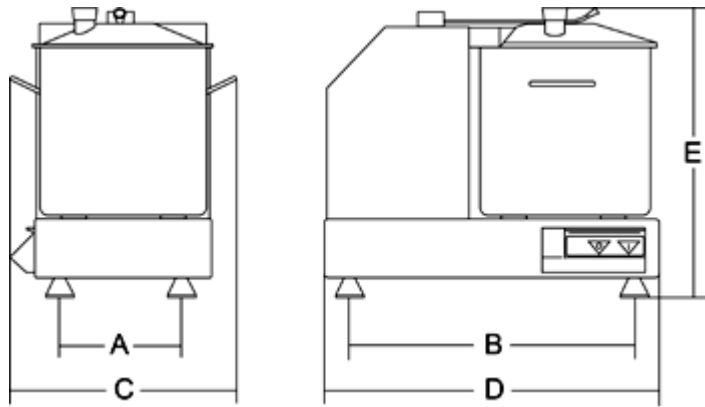

Modèle	C9 VV
Puissance	Watt 350+350 - Hp 0,5+0,5
Capacité cuve	Lt. 9,4
Capacité utile cuve	Lt. 5,4
Tours/m	rpm 1500÷2800
A	mm 225
B	mm 410
C	mm 355
D	mm 455
E	mm 380
Poids net	Kg 23
Dimensions emballage	mm 720x350x500
Poids brut	Kg 25

1.3.3 - CUTTER components

FIG. n°1 - General view of the CUTTER

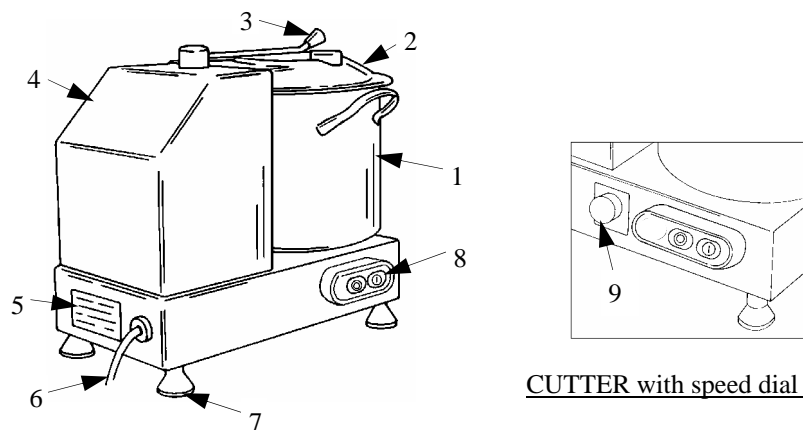

CUTTER with speed dial knob.

LEGEND:

- | | |
|---------------------------------------|-----------------------------------|
| 1 - Basin | 6 - Power supply cord |
| 2 - Lid | 7 - Feet |
| 3 - Closing arm | 8 - Push-button panel |
| 4 - Body | 9 - Speed dial knob (for mod. VV) |
| 5 - Information plate - serial number | |