

11/2017

Mod: 300/BS

Production code: MIRRA 300 CE



Diamond
catering equipment



- Anodized cast aluminium alloy.
- Great distance between blade and motor for easy cleaning.
- Ventilated motor.
- Forged, hardened large thickness blades.
- Carriage running on self-lubricating bushes and lapped pins.
- Stainless steel screws and slice deflector.
- Strong thickness gauge support.
- Cast-in sharpener assembly.
- Compact dimensions and great cutting capacity.
- CE professional with device for releasing the carriage.
- Teflon coated or toothed blades are available on demand.
- 25° blade inclination.



Enclosed and sealed belt pulley standard



More space between blade and body machine



Device for releasing the carriage

Data sheet

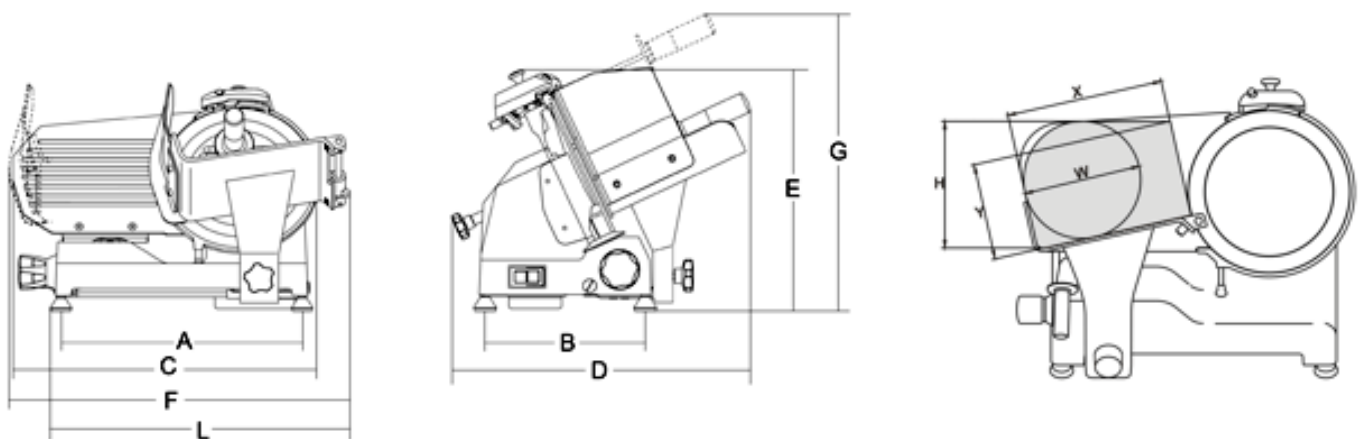

Model	Mirra 300 Y09
Blade:	mm 300 - inch. 12
Motor:	watt 210 / Hp 0,29
Cut thickness:	mm 13
Run of carriage:	mm 285
Hopper:	mm 250x275
A:	mm 435
B:	mm 295
C:	mm 600
D:	mm 610
E:	mm 420
F:	mm 640
G:	mm 510
L:	mm 535
X:	mm 250
Y:	mm 185
H:	mm 225
W:	mm 210
Net weight:	kg 20,5
Shipping:	mm 800x600x520
Gross weight:	kg 23,5
HS-CODE:	84385000