

05/2015

Mod: 350/VCS-N

Production code: 15352502S



Diamond
catering equipment

Slicers, model Mantegna 350 VCS Top:

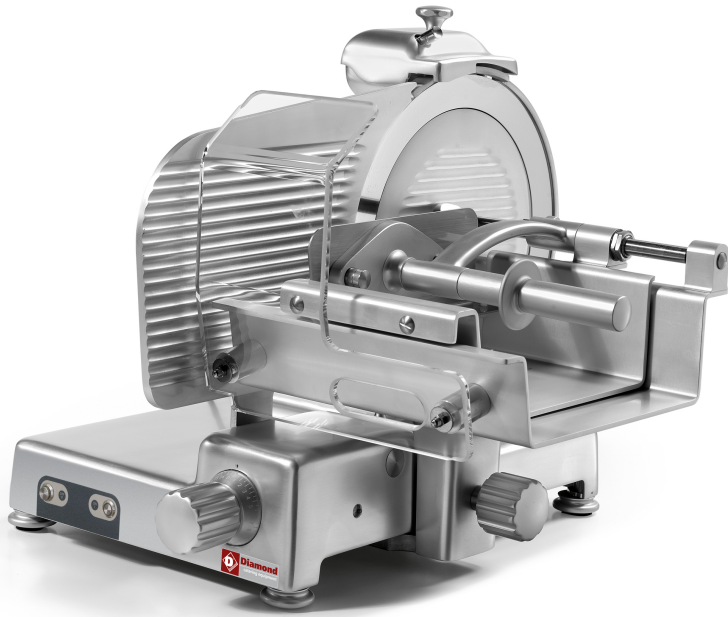

- Innovative rounded design and no sharp edges or visible screws
- Chrome plated ground and lapped slide rod
- Lapped cast iron slide rod bushing
- Vulcanised rubber stops on carriage
- Removable support cover for thickness gauge plate
- Stainless steel slice deflector with snap-on bayonet fitting
- Stainless steel screws and fittings
- Bottom cover for accessing electrical components
- Changeover electronic circuit 110-220-380 V single and three-phase - Built-in sharpening tool with bottom protection
- Aluminium knobs
- Aluminium telescopic feet with rubber base
- Stainless steel pushbuttons with IP67 protection rating
- Maintenance tool kit and demo CD
- 48 mm distance between blade and motor.



Removable food pusher VCS



Incorporated sharpener



Controls on body (push-buttons IP67)

Data sheet

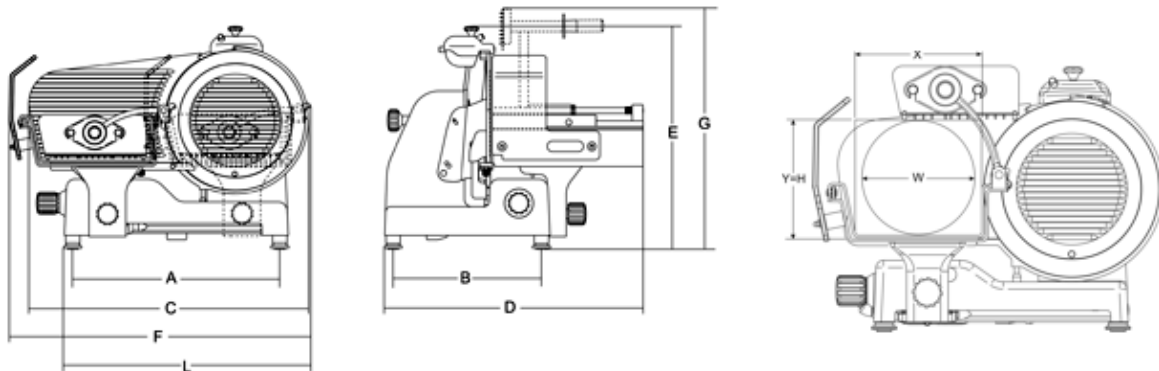

Technical data

Model	MANTEGNA 350 VCS TOP
ø blade	mm 350 - inch. 14
Motor	watt 370 - Hp 0,50
Cut of thickness	mm 29
Run of carriage	mm 310
Hopper	mm 340x250
A	mm 468
B	mm 338
C	mm 660
D	mm 685
E	mm 530
F	mm 720
G	mm 560
L	mm 580
X	mm 250
Y	mm 245
H	mm 245
W	mm 245
Net weight	kg 38
Shipping	mm 870x840x750
Gross weight	kg 54
HS-CODE	84385000